

AS5859-02

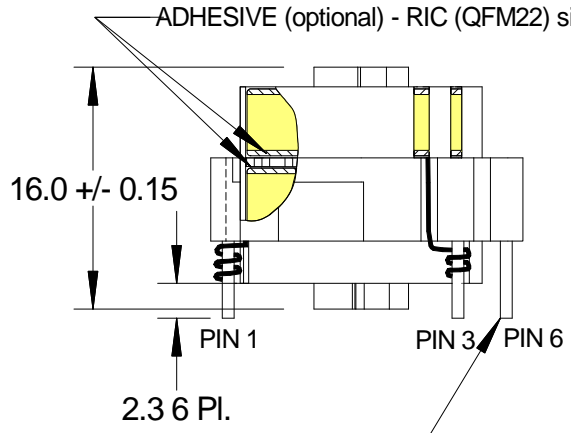

NOTES:

1. Frame Material - R/C(QMFZ2) designated Zytel 70G33L, manufactured by E.I. Dupont rated 130°C max.
2. Sensing Toroid - Magnetic Metals P/N 5029 (80% Nickel Iron Alloy Rings) with 1000 turns of coated magnet wire, 40 AWG, 45 Ω +/- 10%, Wire is R/C (OBMW2) type Polysol 155 from Elektrisola or equivalent.
3. Grounded Neutral Toroid - Magnetic Metals P/N F3006 (Ferrite Material) with 300 turns of coated magnet wire, 40 AWG, 16 Ω +/- 10%, Wire is R/C (OBMW2) type Polysol 155 from Elektrisola or equivalent.
4. Shield Washer - Material - M6 silicon steel, circular dimensions - 0.36 mm thick, OD=14.48 mm, ID=6.60 mm
5. Insulator - Material - nylon, circular dimensions - 0.3 mm thick, OD=14.4 mm, ID=6.15 mm
6. Maximum operating temperature = 85°C

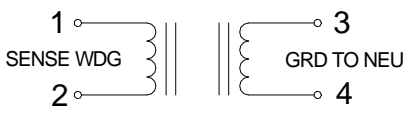

SCHMATIC

All Dimensions in Millimeters

REVISIONS
REV 2 - 12/6/06 - Corrected pin number - D.ROLLINS.
4. All dimensions in millimeters.
REV 3 - 12/8/06 - Added additional dimensions, changed to metric - D.ROLLINS.
REV 4 - 3/20/07 - Corrected Pin 5 location dimension - D. Rollins
REV 5 - 5/3/07 - Changed Pin Size from 0.91 to 0.635, changed material from Zytel 101L to Zytel 70G33L. - D. Rollins
REV 6 - 5/30/07 - Changed 11.06 dimension to 9.96 - D.ROLLINS
REV 7 - 3/13/08 - Added Insulator and Shield Waser, Added Notes 5,6, & 7. Added Schematic. - D. Rollins
Rev 8 - 1/15/09 - Changed 9.96 dimension to 9.60, redrawn in ACAD format, Added shield washer insulator.

THIS DRAWING IS THE PROPERTY OF MAGNETIC METALS . COPIES ARE ISSUED IN STRICT CONFIDENCE AND SHALL NOT BE REPRODUCED OR COPIED OR USED AS THE BASIS FOR THE MANUFACTURE OR SALE OF APPRATUS WITHOUT WRITTEN PERMISSION.

MATERIAL	
FINISH	
DRAWN D. Rollins	DATE 12/05/06
APPROVED	DATE

TOLERANCES	
± 0.13 mm	
ANGLES ± .5°	
UNLESS OTHERWISE SPECIFIED	

Magnetic Metals Corporation  
1900 Hayes Avenue  
Camden, NJ 08105

GFCI COIL ASSEMBLY

A	DRAWING NUMBER		REV
	AS5859-02		
SIZE	SHEET NO	1 OF 1	